

SURFACE DOOR CLOSER

Installation Instructions

PK100090

These closers are suitable for either hand of door and include two separate adjustment valves for latch and sweep speed. Maximum angle of opening 180° (conditions permitting)

	INTERIOR/EXTERIOR	DOOR WIDTH			
		INCHES	INCHES	INCHES	INCHES
		2' 0"	2' 6"	3' 0"	3' 6"
641	INTERIOR	✓	✓	♿	♿
	EXTERIOR	✓	✓	♿	—
643, 644 & 645	INTERIOR	—	—	643	644
	EXTERIOR	—	643	644	645

REFER TO ATTACHED INSTRUCTION SHEETS FOR INSTALLATION

IMPORTANT

This closer must be installed by a competent technician who should pass these instructions on to the site or maintenance manager. No responsibility can be accepted by the manufacturer if these installation instructions are disregarded.

Door must swing freely and close easily to enable closer to operate efficiently.

A separate door stop is recommended to limit maximum door swing and to prevent damage to frame, door and installed hardware.

MAINTENANCE

Quarterly check door closer adjustments and make sure all fasteners are tight. Lubricate arm knuckle and door hinges.

UNDER NO CIRCUMSTANCES should the door closer be dismantled.

REGULAR ARM INSTALLATION
Pull Side Application
 Refer to chart below for hole placement
 See page 5 for adjustments

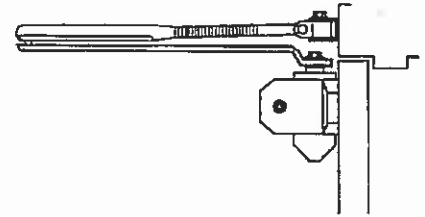
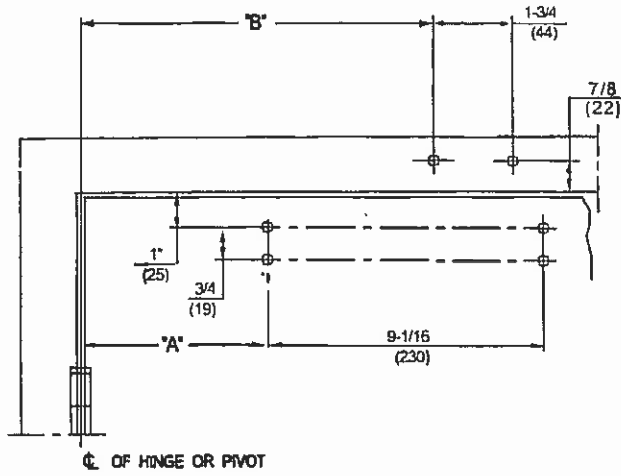
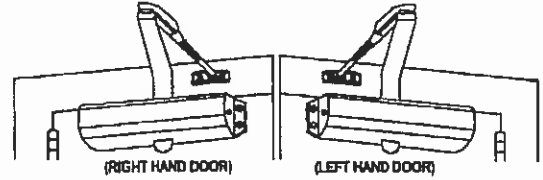

- Right hand door illustrated
- Do not scale drawing
- Dimensions are in inches/millimeters

INSTALLATION INSTRUCTIONS

1. Select degree of opening. Use dimensions shown to mark location of attaching screws on door and frame . Prepare holes (See notes).
2. Assemble main arm to closer.
3. Attach closer to door with speed regulating valves toward hinge.
4. Attach the foot of the forearm to frame.
5. Adjust length of forearm to position forearm at right angle to frame when connected to main arm at elbow. Use washer and screw provided to secure pivot connection. Tighten locknut on forearm.
6. Snap pinion cap cover over spindle at bottom of closer.
7. Adjust closer. Reference page 5.

Position of arm and index settings

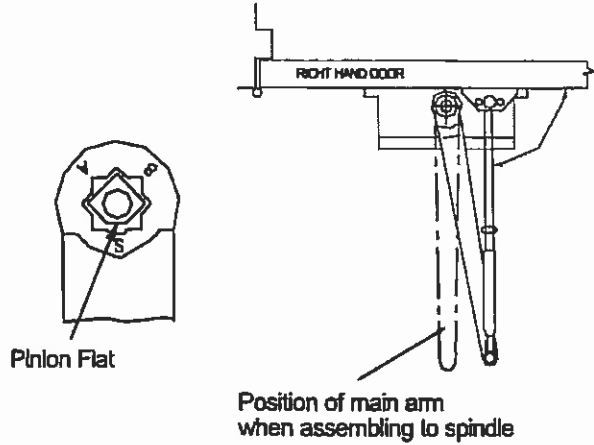

INSTALLATION DIMENSIONS

OPENING	DIM. "A" CLOSER		DIM. "B" ARM SHOE	
	INCHES	MM	INCHES	MM
TO 100"	7"	(178)	13"	(330)
100" TO 120"	6"	(152)	12"	(305)
OVER 120"	3-1/2"	(89)	9-1/2"	(241)

NOTES:
 FOR 1/4-20 MACHINE SCREWS USE #7 DRILL
 FOR NO. 14 WOOD SCREWS USE 5/32" DRILL
 DO NOT SCALE DRAWING.
 DIMENSIONS ARE IN INCHES/MILLIMETERS.

TOP JAMB INSTALLATION

Push Side Application

Refer to chart below for hole placement
See page 5 for adjustments

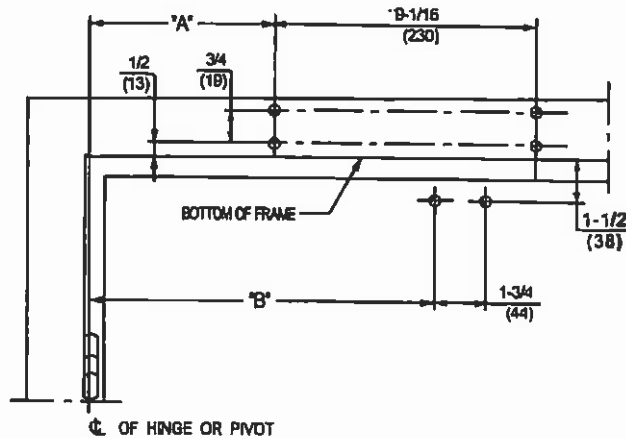
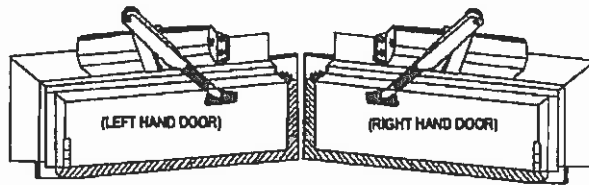

Position of arm and index settings

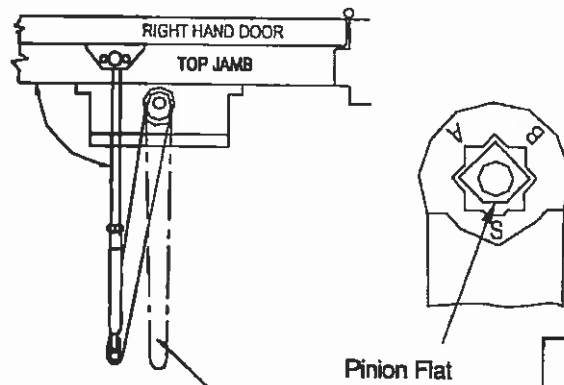

Position of main arm
when assembling to spindle

NOTES:
FOR 1/4-20 MACHINE SCREWS USE #7 DRILL
FOR NO. 14 WOOD SCREWS USE 5/32" DRILL
DO NOT SCALE DRAWING.
DIMENSIONS ARE IN INCHES/MILLIMETERS.

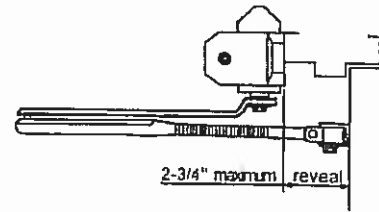

- Right hand door illustrated
- Do not scale drawing
- Dimensions are in inches/millimeters

INSTALLATION INSTRUCTIONS

1. Select degree of opening. Use dimensions shown to mark location of attaching screws on door and frame. Prepare holes (See notes).
2. Assemble main arm to closer.
3. Attach closer to frame with speed regulating valves toward hinge.
4. Attach the foot of the forearm to door.
5. Adjust length of forearm to position forearm at right angle to frame when connected to main arm at elbow. Use washer and screw provided to secure pivot connection. Tighten locknut on forearm.
6. Snap pinion cap cover over spindle at bottom of closer.
7. Adjust closer. Reference page 5.

INSTALLATION DIMENSIONS

OPENING	DIM. "A" CLOSER		DIM. "B" ARM SHOE	
	INCHES	MM	INCHES	MM
TO 100°	7-1/2"	(191)	13-1/2"	(343)
100° TO 120°	6"	(152)	12"	(305)
OVER 120°	3-1/2"	(89)	9-1/2"	(241)

PARALLEL ARM INSTALLATION

Refer to chart below for hole placement
See page 5 for adjustments



CLOSER

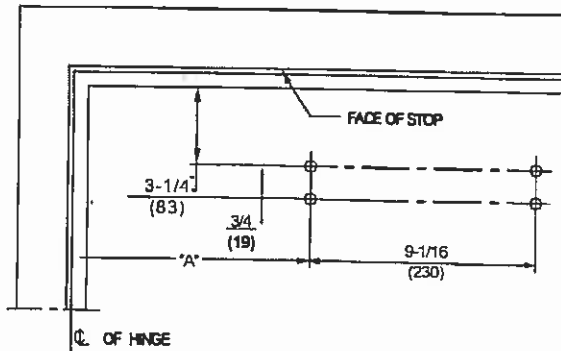
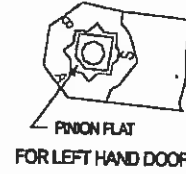
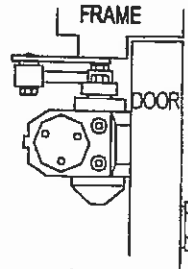

PARALLEL ARM BRACKET

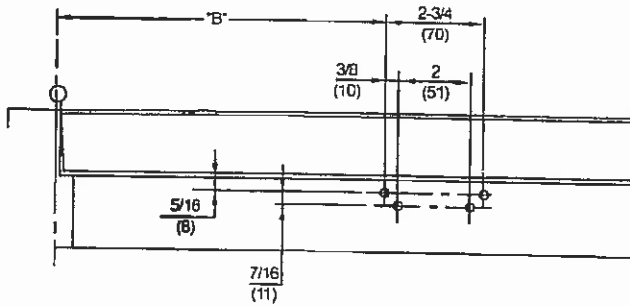

INSTALLATION DIMENSIONS

OPENING	DIM. "A" CLOSER		DIM. "B" PA BRACKET	
	INCHES	MM	INCHES	MM
TO 100°	7-5/8"	(194)	9-1/4"	(235)
100° TO 130°	6-1/8"	(156)	7-3/4"	(197)
OVER 130°	4-1/8"	(105)	5-3/4"	(146)

NOTES:

FOR 1/4-20 MACHINE SCREWS USE #7 DRILL
FOR NO. 14 WOOD SCREWS USE 5/32" DRILL
DO NOT SCALE DRAWING.
DIMENSIONS ARE IN INCHES/MILLIMETERS.

- Right hand door illustrated
- Do not scale drawing
- Dimensions are in inches/millimeters

INSTALLATION INSTRUCTIONS

1. Select degree of opening. Use dimensions shown above to mark location of attaching screws on door and frame. Prepare holes (See notes).
2. Attach closer to door with speed regulating valves toward latch.
3. Attach PA bracket to stop as shown.
4. Remove foot from forearm and discard.
5. Install arm on pinion shaft. Rotate pinion 45° toward hinge edge of door to align main arm letter "B" (right hand door) or "A" (left hand door) with pinion flat. Fasten with arm screw.
6. Fasten forearm to PA bracket.
7. Adjust forearm to length to position arm elbow about 1-1/2" from door when connected to main arm. Use washer and screw provided to secure pivot connection. Tighten locknut.
8. Snap pinion cap over spindle at bottom.
9. Adjust closer. Reference page 5.

CRITICAL ADJUSTMENTS

PK100090

Closing Speed Control

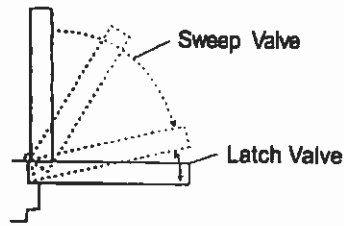

Adjust closing speed time to between 4 to 6 seconds from 90°. Barrier free access may require longer closing time.

Opening Door Control

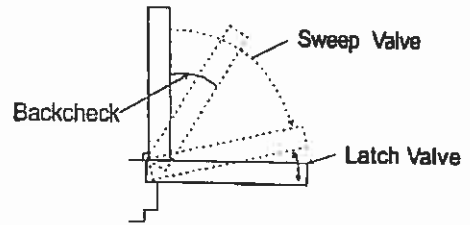

Backcheck (BC) valve controls the hydraulic resistance to door opening in backcheck range. NEVER close the valve completely, it is not to provide a positive stop.

REGULATING DOOR SPEED AND LATCHING SPEED

Turn valves clockwise to slow down or counter clockwise to speed up door movement.

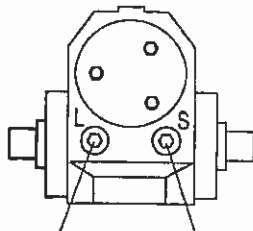

LATCH VALVE SWEEP VALVE

REGULATING SPRING POWER (640 Series closer) REGULATING BACKCHECK POWER

Adjust only if more spring tension is required to positively close and latch door. Turn clockwise. DO NOT exceed the maximum turns. "18-360° turn available from minimum setting."

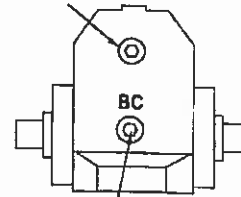

Turn backcheck regulating valve clockwise to increase or counter clockwise to decrease intensity. NEVER close this valve completely.

ADJUSTING FOOT FOR CLOSING POWER

Move foot pivot as illustrated below.

Less Power More Power

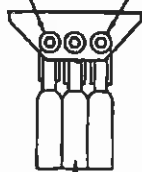

Standard Position

caution: Do not back any valves out of closer or a leak will result.